



# Model 745-OEM

## Compact Digital Delay Generator

### FEATURES

- Four high-resolution delay channels  
0.25 ps resolution  
< 5 ps RMS jitter (at short delay)  
> 20-second delay range
- Adjustable outputs (2 to 5 V amplitude, 100 ns to 10  $\mu$ s width). 1 ns rise-time into 50  $\Omega$
- Triggers: Burst, Gate, External trigger pre-scaler, Internal frequency generators
- External clock: 10 MHz up to 100 MHz
- Compact packaging
- All parameters may be controlled via Ethernet or Internet, or USB
- Option: Four auxiliary delay channels

### APPLICATIONS

- Embedded OEM applications
- Component Testing/QC
- ATE Applications
- Laser system timing Control
- Laser Pulse Picking
- High Precision Pulse/Gate
- Instrument Triggering



### DESCRIPTION

The Model 745-OEM is a compact digital delay generator intended for use in embedded OEM applications. The module Delay Generator provides four or eight independent delayed pulses. Delay up to 20 seconds can be programmed with 0.25 ps resolution and the external trigger-to-channel jitter is less than 25 ps.

MCX output connectors deliver 5 V, 1 ns rise-time into 50  $\Omega$ . Pulse amplitude and width are adjustable on each output channel.

One input trigger, or two internal synchronized timers, or software commands may be used to trigger all output channels.

One T0 output pulse (marking zero delay reference) is generated at each selected trigger.

The Model 745-OEM also provides (as an option) four auxiliary delay channels T5 to T8. The delay resolution is 1.25 ns and the trigger-to-channel jitter is less than 50 ps.

Model 745-OEM parameters can be controlled via Ethernet (10/100 Mb/s) or Internet (Web page from Internal Web server) or USB.



# Model 745-OEM

## Compact Digital Delay Generator

### SPECIFICATIONS

<b>Delay channels T1 to T4</b>	
Number	4 independents (or 8 in option)
Range	0 to > 20 seconds
Resolution	0.25 ps
RMS jitter	25 ps + delay x 10 <sup>-8</sup> (external trigger to any output) 5 ps + delay x 10 <sup>-8</sup> (internal trigger to any output)
Accuracy	< 250 ps + delay x 10 <sup>-8</sup>
Timebase	0.05 ppm stability
<b>External Trigger Mode</b>	
Input Trigger	Threshold = 0.1 to 5 V into 50 Ω, Slope = positive or negative
Repetition rate	Single, Repetitive < 1 MHz, or Burst mode
Trigger prescaler	1 to 2 <sup>16</sup> -1
Trigger delay	< 65 ns (insertion delay)
<b>Internal Trigger Mode</b>	
Rate repetitive	From two Timers with frequency = 0.25 Hz to 1 MHz (in steps of 5 ns)
<b>Channel Output pulse A to D</b>	
Amplitude	2 V to 5 V in steps of 10 mV
Load	50 Ω
Rise/Fall Time	< 1 ns / < 3 ns
Width	100 ns to 10 μs, 5 ns resolution
Pulse Polarity	Positive
Burst Mode	From 1 to 2 <sup>16</sup> -1
Connector	MCX
<b>Clock IN</b>	
Threshold	0 V, internal 50 Ω
Level	Min -3 dBm
Frequency	10 MHz (or request any frequency up to 100 MHz when ordering from factory)
<b>Clock OUT</b>	
Frequency	10 or 80 MHz (or request any frequency up to 100 MHz when ordering from factory)
Level	+/-1 V into 50 Ω
Shape	Square
<b>Gate</b>	
Input	Active high, threshold 1.5 V, positive or negative slope,
Function	Output inhibit (Global or individual channel)
<b>T0 output</b>	
Amplitude	5 V / 50 Ω, 200 ns width
<b>General</b>	
Interface Control	USB to UART, Ethernet 10/100Mb/s
User memory	Up to 4 sets of parameters can be stored/recalled via Ethernet or USB
Software tools	Free Drivers for Windows 10
Power consumption	25 W
Power supply	+12 V - 0.6A / + 5 V - 3A
Weight	<1 kg
Size	176 x 128 x 35 mm
<b>Option 8C: Four auxiliary channels (T5 to T8)</b>	
Delay channel	Channel output pulse
Number: 4 independents	Amplitude: 2.5 to 5 V / 50 Ω, common tuning
Range: 0 to > 20 seconds	Width: 100 ns to 10 ms, 5 ns resolution
Resolution: 1.25 ns	Rise and fall time: <5 ns
Jitter: <50 ps RMS + delay x 10 <sup>-8</sup> (external trigger to any output)	Connector: MCX
Accuracy: 1 ns + delay x 10 <sup>-8</sup>	
<b>Option NP: Narrow Pulse</b>	
Provide pulse up to 5 ns width, on the output T1 and T3 adjustable in steps of 0.25 picoseconds.	



# Model 745-OEM

## Compact Digital Delay Generator

### FUNCTIONAL OVERVIEW

#### Block diagram

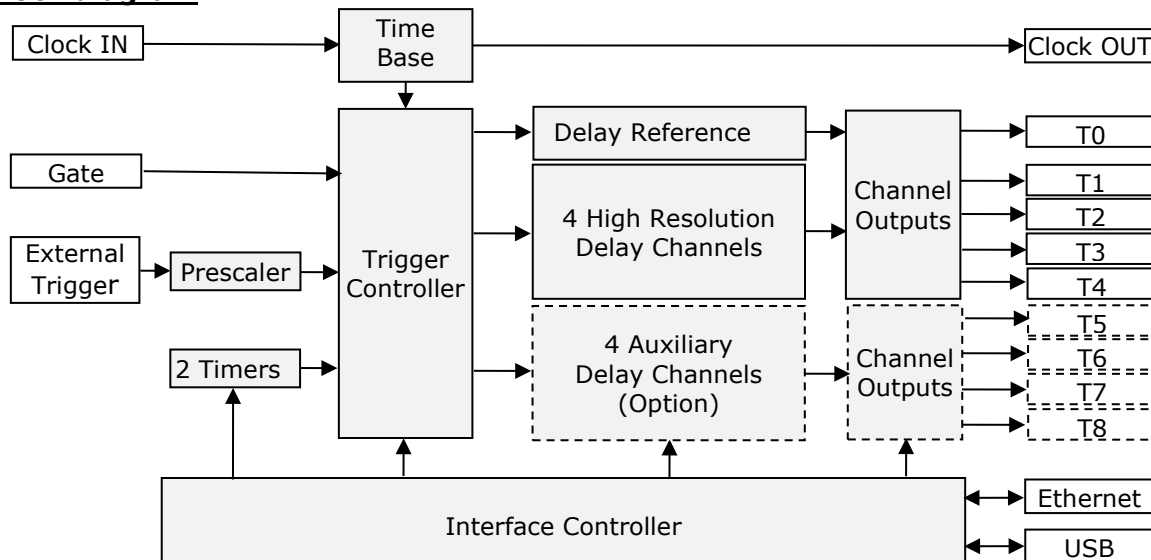

#### Timebase

The time base is provided from an internal clock reference or an external 10 MHz clock (Clock IN). As an option, the external clock can be up to 100 MHz.

#### Delay channel

There are four independent delay channels. The delay from the selected trigger source is adjustable up to 20 seconds in 1 ps increments.

Jitter: The following chart indicates typical RMS jitter at various delays:

Internal Trigger Mode	External Trigger Mode
Delays < 100 ns: 5 picoseconds	Delays < 100 ns: 5 picoseconds
Delays > 100 ns: 15 picoseconds + time base	Delays > 100 ns: 25 picoseconds + time base

#### Triggering

The Model 745-OEM offers users several methods for triggering delay channels:

- Externally trigger on the positive or negative slope of your trigger signal and selected level from 0.1 V to 5.0 V.
- Internally from two adjustable timers from 0.25 Hz to 1 MHz in 1 Hz increments (5 ns).
- Remotely from software trigger command.

#### Trigger Modes

Burst mode: pulse number 1 to  $2^{16}-1$ , period 1000 ns to 1 second (depending on the trigger rate)

Trigger Pre-scaler: pre-scaler value applied to the external trigger goes from 1 to  $2^{16}-1$

Gate mode: can be set to global or individual channel.

#### Outputs

Each delay channel output pulse is independently adjustable in level and width. The outputs are designed to drive an external 50  $\Omega$  load. T0 Output pulse is a time reference that marks zero delay.

#### Interface Control

All parameters may be remotely controlled over an Ethernet network or USB interface.

Model 745-OEM has an embedded control interface software that allows all parameters to be controlled by any PC with a standard browser.

### Example of channel outputs mode

- Repetitive and single trigger

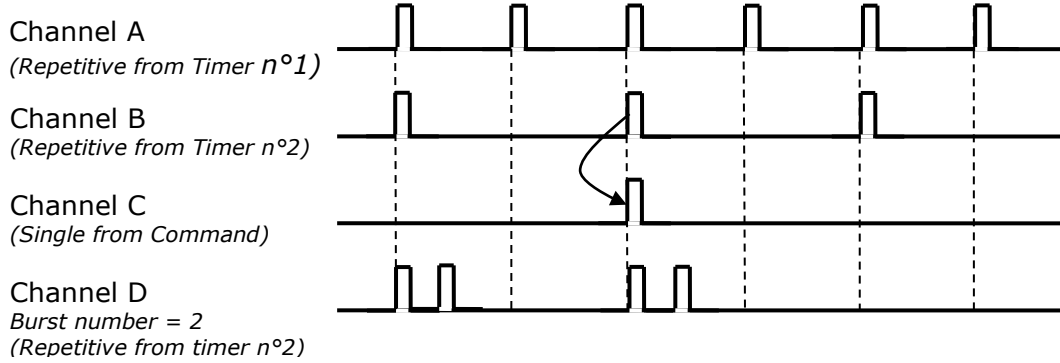

- Pulse picking

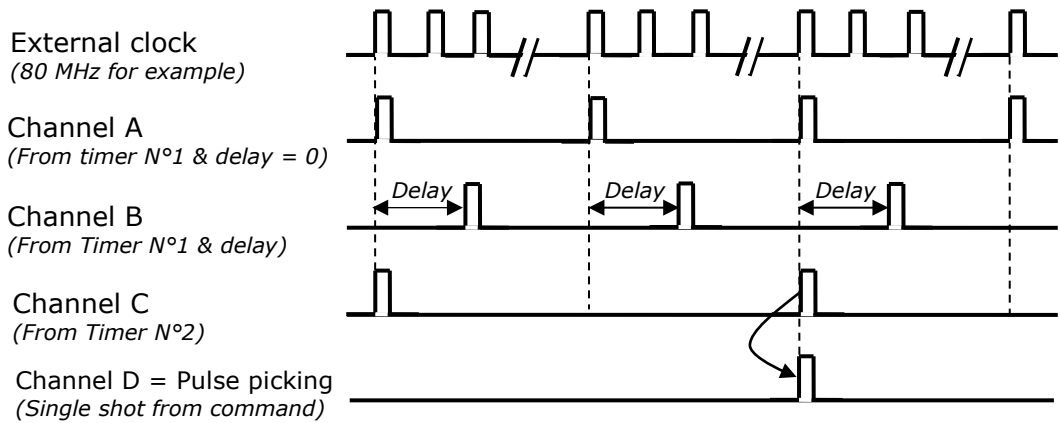

**"Narrow pulse option"** provides a pulse as narrow as <math><10\text{ ns}</math>, on the outputs T1 and T3. The value of the width is adjustable in steps of 0.25 ps. The narrow output pulse is achieved by ANDing two channel outputs.

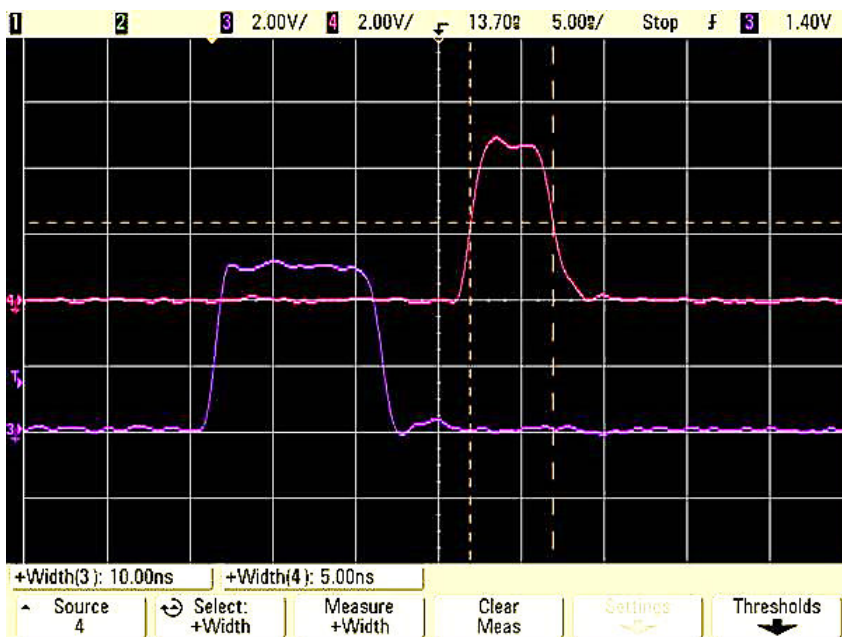

5 ns/div and  
2 V/div

*T1 set to 10 ns (in purple) and T3 set to 5 ns (in pink)*



# Model 745-OEM

## Compact Digital Delay Generator

### CONTROL AND SOFTWARE TOOLS

They are two ways to control the generator:

**"Easy remote way"** via Internet and control panel web pages.

Web page, from the embedded Web server, provides a simple method to configure settings for each channel (delay, output amplitude, polarity, output width, trigger mode, trigger source), to control operation and to display the status of the instrument.

The configuration information of the instrument is stored and saved in the Model 745 OEM.

The web page can be opened via Internet Explorer, Mozilla, Firefox, or Chrome without specific software.

After connecting a cable from the Model 745 OEM's Ethernet port to your computer network, enter the Model 745 OEM's IP address into your PC's browser. The browser will automatically open the control panel web page on your PC.

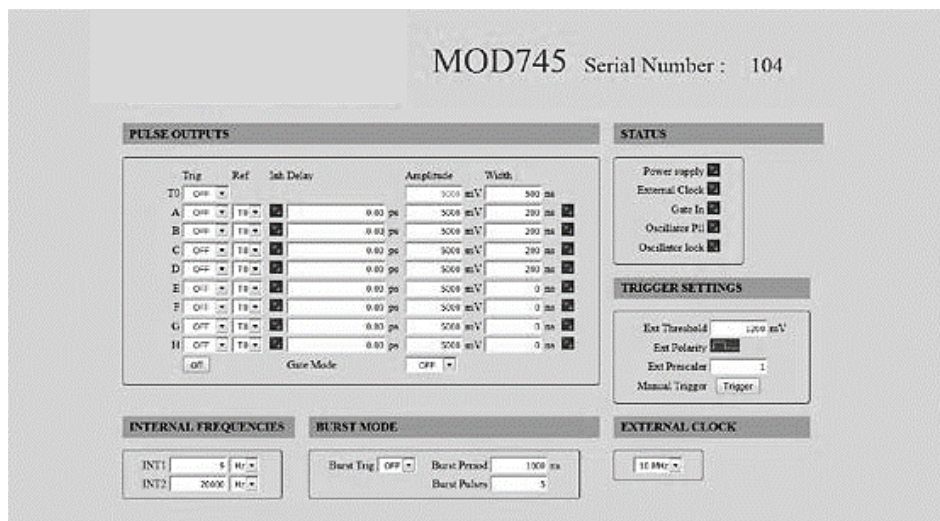

Setup Web page

**"General remote way"** via BNC software application or another PC software application.

### INPUT / OUTPUT INTERFACE

Top view of the generator

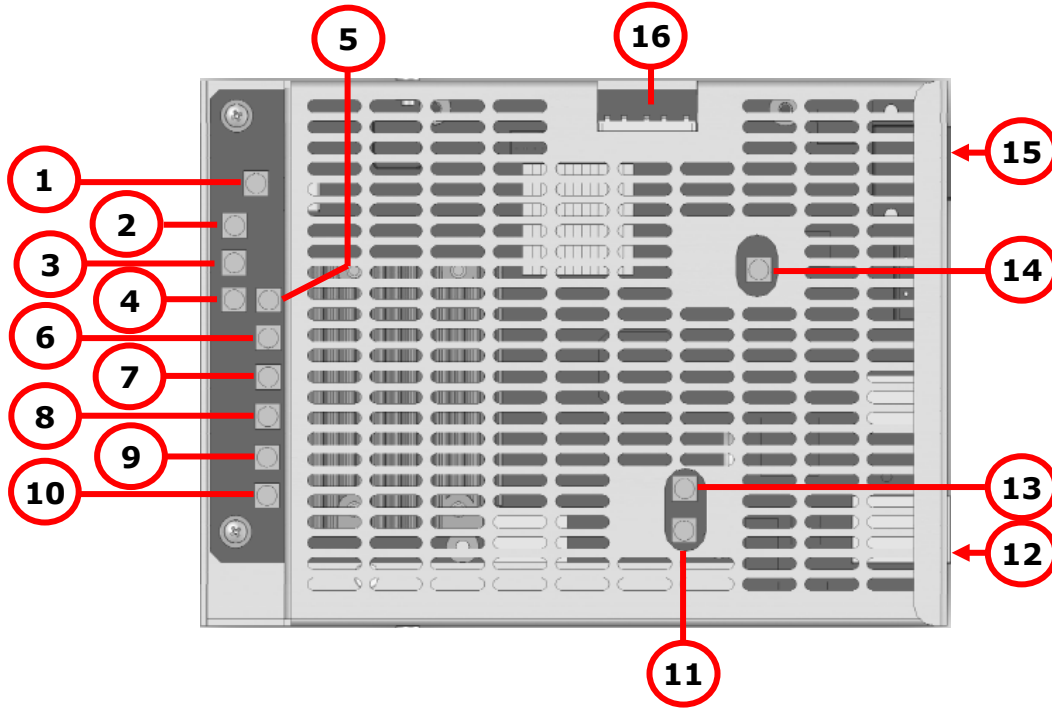

#### Connectors

1	Trigger Input: MCX connector	9	T1 Output: MCX connector
2	T5 Output: MCX connector	10	T0 Output: MCX connector
3	T6 Output: MCX connector	11	Clock Input: MCX connector
4	T7 Output: MCX connector	12	Ethernet: RJ45 connector
5	T8 Output: MCX connector	13	Clock Out: MCX connector
6	T4 Output: MCX connector	14	Gate Input: MCX connector
7	T3 Output: MCX connector	15	USB interface: micro-USB connector
8	T2 Output: MCX connector	16	Power input: AMP connector

### ORDERING INFORMATION

Model	Description
Model 745-OEM	Base version: 4 high-resolution delay channels
Model 745-OEM-8C	Option 1: Adds 4 auxiliary channels
Model 745-OEM-NP	Option 3: Narrow pulses on T1 and T3

### ACCESSORIES (Pulse shaping modules)

Model	Description
GFT101	Electrical-to-optical Pulse Converter
GFT400	500 ps, 2 V under 50 $\Omega$ Pulse Generator
GFT500	200 ps, 4 – 9 V under 50 $\Omega$ Step Generator
GFT632	32 – 70 V, 3 ns rise time under 50 $\Omega$ Pulse Generator
GFT644	4 channel 50 $\Omega$ Line Driver Module