



GFT1504

4/8/10 channel Delay Generator

Features

- 4 independent Delay Channels (10 in option)
100 ps resolution (1ps in option)
25 ps RMS jitter (channel to channel)
10 second range
- Channel Output pulse
6 V/50 Ω, 3 ns rise time
Independent control of width, polarity and amplitude
- Independent trigger rate (repetitive or single) for every channel
- External trigger mode from external input or Internal trigger mode from two synchronous programmable timers
- External Clocking up to 90 MHz (in option)
- Controlled via Front panel, Ethernet, Internet (Control panel Web page)
- Compact packaging
- Options
 - Extension to 8 or 10 delay channels
 - Channel Output amplitude 10V or 20V or 32V under 50Ω, or Optical pulse



Applications

- ATE application
- System Laser timing control
- Laser pulse piking
- Precision pulse Application
- Instrument triggering
- Components test

Description

The GTF1504 Digital Delay Generator provides up to ten independent delayed pulses. Delays up to 10 seconds can be programmed with 100 ps resolution and channel to channel jitter is Less than 25 ps rms. BNC outputs deliver up to 6 V, 3 ns rise time under 50 Ω. Pulse amplitude, width and polarity are adjustable on each output channel. In option pulse amplitude can be 2.5 to 10 V or 5 to 20 V or fixed 32 V or optical pulse.

The generator provides two trigger mode to trigger delay channel: External mode from one input trigger or Internal from two synchronous programmable timers. Each channel can be single or repetitive trigger rate.

GFT 1504 parameters can be local controlled over the front panel keys and LCD display and remote controlled via Ethernet (10/100Mb/s) or Internet (Web page from Internal Web server). This "web page" provides a simple method to configure the settings on each channel and to control operation.

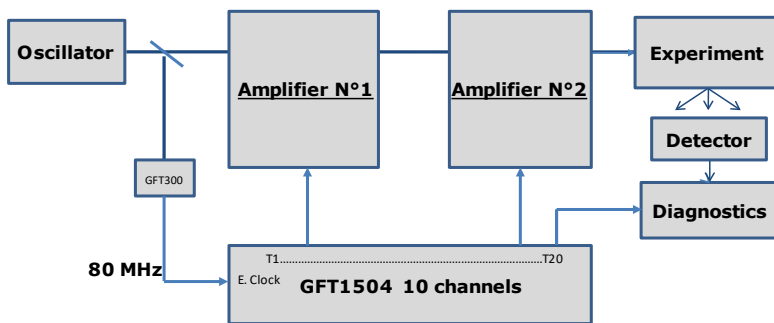

Typical picosecond laser system

Application laser pulse piking

The GFT1504 is well suited in laser pulse picking application to synchronize all the equipment of a Laser System with only one compact unit and one Control command. In this application external clock (CLK IN) of GFT1504 Delay Generator receive an 80 MHz frequency from laser oscillator. Each Amplifier (Pump-laser, Q switch, Pockel cell...), or instrument for several kinds of diagnostics (Photodiode, Digitizer, Oscilloscope, Calorimeter, CCD camera and Steak camera...) can received repetitive or

single pulses (adjusted in rate, delay, amplitude, width) and synchronized on 80MHz external clock with a very low jitter.



GFT1504

4/10 channel Delay Generator

Specifications

Delay channels	
Number	4 independents (up to 10 in option)
Range	10 seconds
Resolution	100 ps (1ps see option 8)
RMS jitter	35 ps + delay x 10 ⁻⁷ (channel to channel) 25 ps for delay <1 μs (channel to channel) 35 ps + delay x 10 ⁻⁷ (External trigger to any channel) 25 ps for delay <1 μs (External trigger to any channel)
Accuracy	< 150 ps + delay x 10 ⁻⁷
Trigger delay	< 100 ns (insertion delay)
Time base	160 MHz frequency, ±50 ppb stability
External Trigger Mode: Source	
Input "TRIG"	Rate single or repetitive up to 100 KHz, +1.35 V / 50 Ω Threshold, slope positive, 5 ns minimum pulse width
Internal Trigger Mode: sources	
Two synchronous timers	Frequency= 1 Hz to 100 KHz (Period= 1 s to 10 μs) Resolution= 6,25 ns
Input "TRIG IN"	Pair of single trigger, 1.35 V/ 50 Ω Threshold, Slope positive
Soft command	Pair of single trigger
Channel Output pulse T1 to T4	
Amplitude	2.5 V to 6 V in step of 10 mV
Load	50 Ω
Rise/Fall time	3 ns (at 5 V) / 5 ns
Width	100 ns to 1 s in step of 6.25 ns
Pulse polarity	Positive or negative
Clock Reference Input	
Threshold	0 V, internal 50 Ω
Level	Min +3 dBm, typical + 10 dBm
Frequency	10 MHz (other frequency are available see option 7)
Clock Output	
Shape, level	Sinewave, >10dBm under 50 Ω
Frequency	80 MHz (½ time base frequency)
Spectral purity	-40 dBm
Gate	
Input	Active high, Threshold 1,35 V, Rate < 1kHz
General	
Interface Control	Front panel, Ethernet 10/100Mb/s, Internet (Web page)
Software tools	Free Drivers for Windows 7/10
Power consumption	90 to 220 V / 50 – 60 Hz/ 50 W
Weight	< 6 kg
Size	237 x 363 x 125 mm
Option	
Option 1:	Extension to 8 channels
Option 2:	Extension to 10 channels
Option 3:	2.5 V to 10V channel output (Width 100 ns to 10 ms, rise/fall time = 0.8/2.4 ns typ. under 50 Ω)
Option 4:	5 V to 20 V channel output (Width=100 ns to 10 μs, rise/fall time = 3/15 ns under 50 Ω)
Option 5:	32 V channel output, With=1 μs, Rise/fall= 3/15 ns under 50 Ω
Option 6:	Optical channel output (250 μW, 850 nm, ST connector)
Option 7:	Other frequency for Clock In and clock Out up to 90MHz (ask to the factory)
Option 8:	1 ps delay channel resolution

GFT1504

4/10 channel Digital Delay Generator

Operating Information

Block diagram of the generator

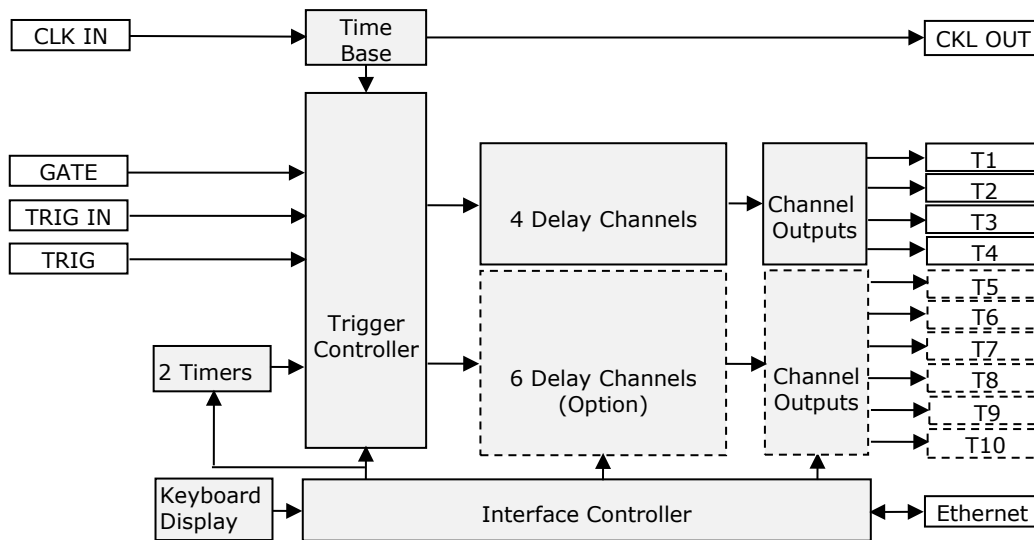

Time base: This functions provides a 160 MHz time base from an internal reference or an external 10MHz reference. In option the external reference can be up to 90 MHz (ask to the factory)

Trigger controller:

This function provides 2 Trigger Modes

-External Trigger Mode: In this mode a rising edge on input "TRIG" trigs all delay channel. On every channel trigger rate can be single or repetitive or inhibited.

-Internal Trigger Mode: This mode provides 4 programmable trigger sources for each channel

- Two are "Repetitive Triggers" from two synchronous timers. Frequency of each timer (IN1 and IN2) is programmable from 1 Hz to 100 KHz. In the normal way the IN1's frequency > IN2's frequency and IN1 must be a multiple of IN2 frequency.
- Two are a pair of "Single trigger" from a rising edge on "TRIG IN" input or from software command (Front panel or Ethernet or Web page). Each single trigger (SS1 and SS2) are synchronous of the lowest Frequency Trigger Generator (IN2). In single-shot experiment application:
 - o "SS1" is used to active low frequency equipment very early to the experiment
 - o "SS2" is used to active fast equipment near or during the experiment like Digitizer or Steak Camera for diagnostics.

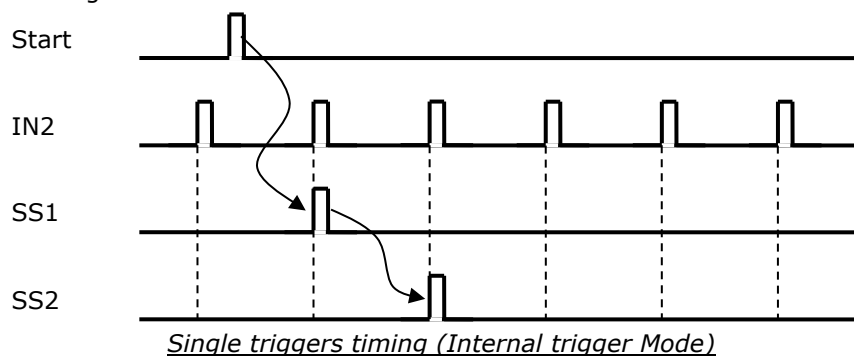

"Gate Input" allows to inhibit quickly all channel Output.

Delay Channel: They are 4 independent delay channels (8 or 10 in option). The delay from selected trigger source is programmable up to 10 seconds in 100 ps increments (1 ps in option)

Channel Output

Each delayed output pulse (T1 to T10) can be independently adjustable in level, width and polarity. The outputs are designed to drive 50 Ω load.

In option every Channel Output level can be 2.5 to 10 V or 5 to 20 V or fixed 32 V or optical pulse (ask to the factory for mixed Channel output level configuration)

Interface Controller manages internal functions and user interfaces. All the parameters can be local controlled over the front panel keys and Display and remote controlled via Ethernet (10/100 Mb/s) or Internet (Web page from internal Web server). All parameters values are automatically saved.

GFT1504

4/10 channel Digital Delay Generator

Control and Software Tools

They are three ways to control the generator:

- **"local way"** via the front Panel Display an Key board

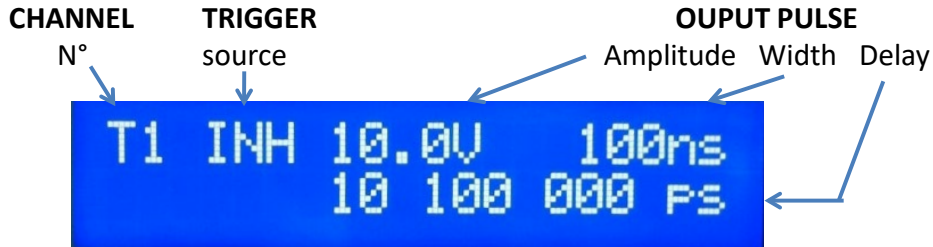

Display example: Settings of Channel T1

- **"Quick remote way"** via Internet and control panel web pages.
 Web page, from embedded Web server, provides a simple method to configure settings for each channel (delay, output amplitude, polarity, output width, trigger mode, trigger source), to control operation and to display the status of the instrument.
 The configuration information of the instrument is stored and saved in the GFT1504.
 The web page can be opened via Edge, Mozilla Firefox or Chrome.
 After connecting a cable from the GFT1004's Ethernet port to your computer network, enter the GFT1004's IP address into your PC's browser (the IP address can be identified or assigned via the front panel). The browser will automatically open the control panel web page on your PC.

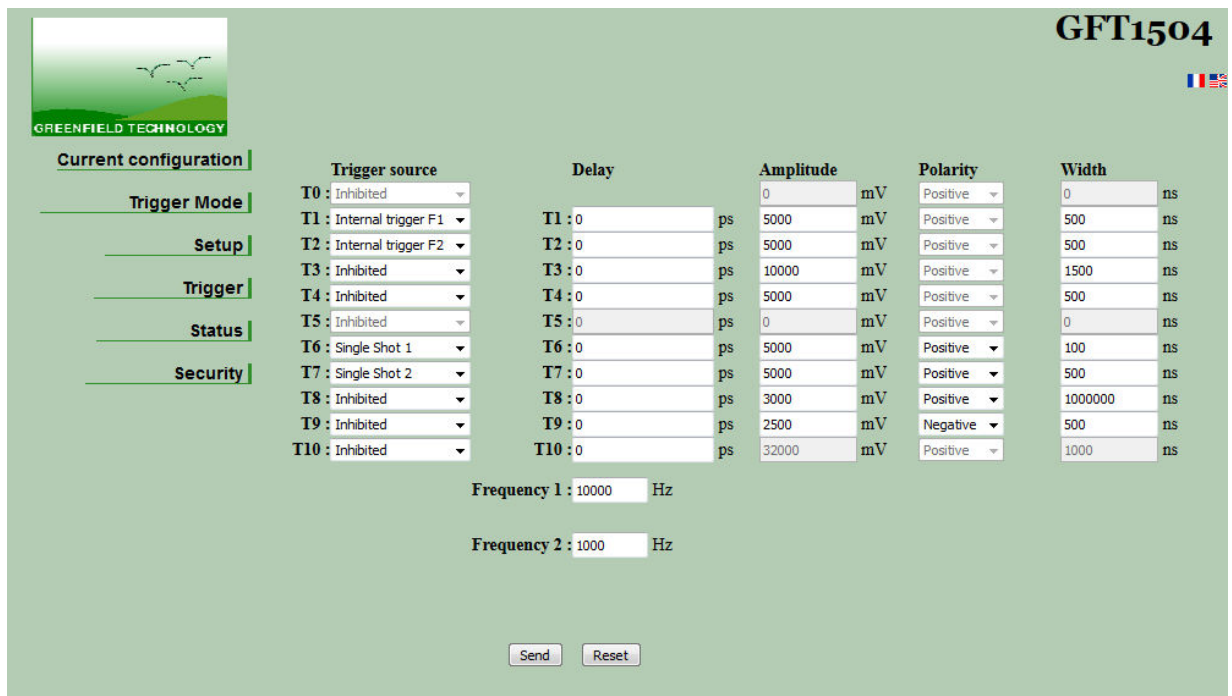

Setup Web page

- **"General remote way"** via LabVIEW software application or other PC software application.

GFT1504

4/10 channel Digital Delay Generator

Front and rear panel interfaces

Front Panel

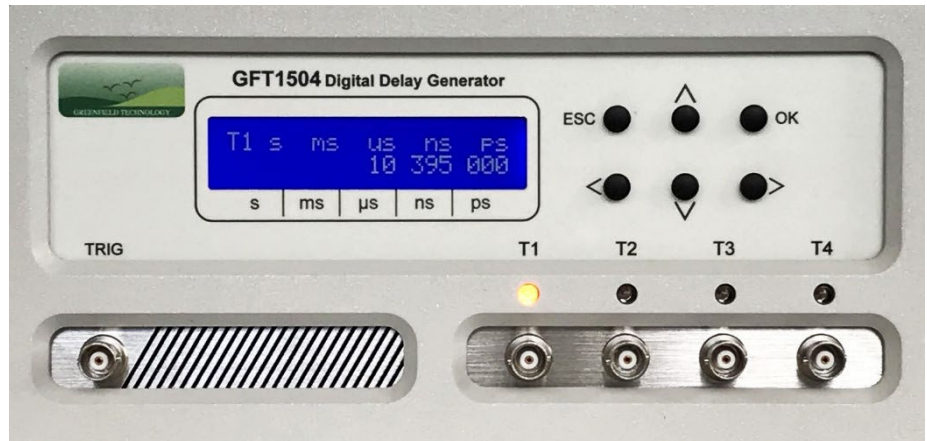

Rear panel



Connector, switch, Indicators

Front panel		Rear panel	
Display	To view settings and status	TRIG IN	Internal mode trigger input: BNC connector
Key board	To local control	GATE	Gate Input : BNC connector
T1 to T4	Pulse outputs: BNC connector	T5 to T10	Channel outputs : BNC connectors
TRIG	Trigger input : BNC connector	CLK IN	Clock input : BNC connector
• <u>Indicators</u>		CLK OUT	Clock output : BNC connector
T1 to T4	Flick at the same frequency as Trigger of channel	LAN	Ethernet connection : RJ45 connector
		Power	Red Switch On/off and plug connector

Ordering Information

GFT1504 Delay generator part numbering

GFT1504-X-X-X-X (Where X is option number)

Ordering examples

GFT1504-1 (GFT1004 with extension to 8 channels)

GFT1504-5-7 (GFT1004 with extension to 10 channels, TTL level channel output)

Accessories (modules to provide specific Output pulse shape)

Model	Description
GFT101	Electrical to optical pulse converter
GFT300	Sub-nanosecond pulse stretcher
GFT632	2ns rise time, 32- 70V under 50Ω Pulse Generator