

# GFT6012

## 3GHz Transient Digitizer

Preliminary product specification

---

### Features

- 5 or 10 GS/s sampling rate
- 10 bits vertical resolution
- 2 channels in only 1U space
- 3 GHz Analog Bandwidth
- Up to 100 M Samples per channel
- Controlled via Ethernet



### Applications

- Diagnostics on Laser system and High-Energy physics
- High speed data acquisition
- Test on high speed circuits
- Automatic Test Equipment

### Description

The GFT6012 is the ideal digitizer for characterizing high speed signal. This compact digitizer can record two analog inputs at speeds of 5 Giga Samples by second (or 10 GS/s on only one analog input) with 10 bits resolution.

A built in Web server provides a remote control of the digitizer via a standard Web Browser. Using it you can set up measurement and display recorded signal.

The GFT6012 is a low profile 19", 1U rack instrument with Ethernet interface.

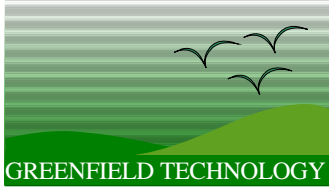

# GFT6012

## 3GHz Transient Digitizer

Preliminary product specification

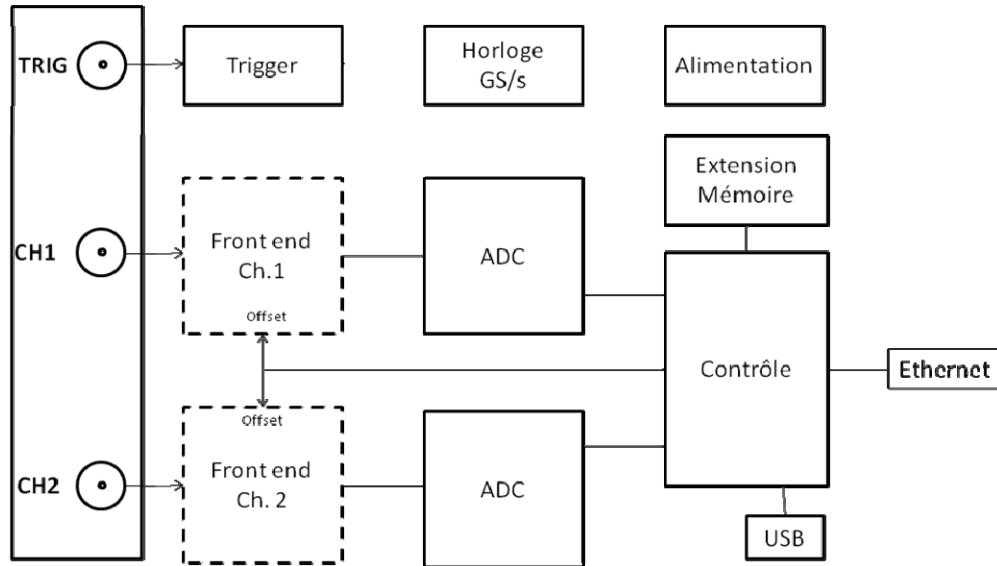

Block diagram

### Specifications

#### Analog input

|                    |                          |
|--------------------|--------------------------|
| Channels           | 2                        |
| Bandwidth          | 3 GHz                    |
| Input impedance    | 50 $\Omega$              |
| Full scale range   | 1 volt                   |
| Offset range       | 10 to 90% off full scale |
| Signal Noise Ratio | 42 dB                    |

#### Digitizer

|               |                          |
|---------------|--------------------------|
| Sampling rate | 5 GS/second              |
| Resolution    | 10 bits                  |
| Memory size   | 10 K samples per channel |

#### External Trigger system

|                 |  |
|-----------------|--|
| Repetition Rate | < 10 kHz   |
| Trigger Level   | Adjustable from 1 to 4V, slope positive, 50 $\Omega$ |

#### General specifications

|       |  |
|-------|--|
| Size  | Rack 19", 1U, 30 cm                      |
| Power | 90 to 240 V, 100 W with a stand by < 10W |

#### Option

|                            |                           |
|----------------------------|---------------------------|
| Option 1: 1 channel        | at 10 GS/s sampling rate  |
| Option 2: Memory extension | 100 M Samples per channel |