



# GFT1404

## 8 Channel Digital Delay Generator

### FEATURES

- Four Tx independent delay channels
  - 1 ps resolution
  - < 50 ps rms jitter
  - > 20 second delay range
- Four ATx auxiliary delay channels
  - One time base period resolution
  - < 100 ps rms jitter
  - > 20 second delay range
- Front panel
- PXI 3U, 1 slot, compact packaging

### APPLICATIONS

- Components test
- ATE
- Laser timing
- Precision pulse
- Instrument triggering

### DESCRIPTION

In system mode, the module is optical triggered by GFT3001 via an optical network.

The GFT1404 module provides four independent delay channels (T0 to T3). The delay resolution is 1 ps, and channel to channel jitter is less than 50 ps. SMB outputs deliver 5 V, 2 ns rise time, under 50  $\Omega$ . Amplitude and width are adjustable on each output pulse.

The GFT1404 also provides four auxiliary delay channels on the PXI bus (PXI trig 0 to PXI trig 3). The delay resolution is one time base period and trigger to channel jitter is less than 100ps.

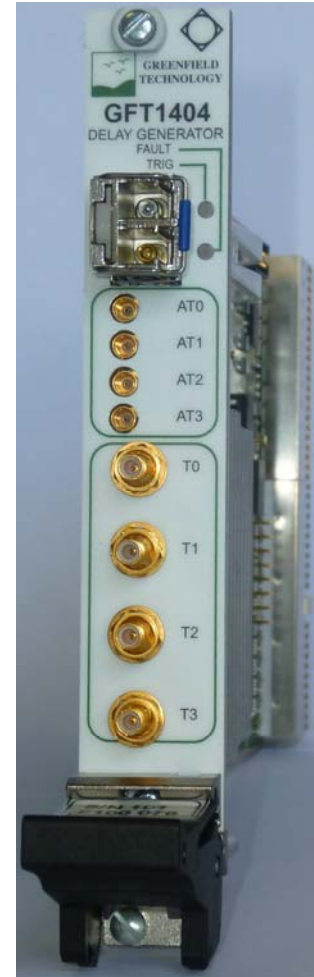

### Control panel software for Windows:

This free software provides a simple method to configure settings for each channel (delay, output amplitude, output width), trigger source, trigger mode, and to control the state of the instrument.

The configuration information of the instrument can be stored to disk and restored.

The software is designed to allow one GFT1404 and multiplied GFT9404 to be installed and operate in the same PXI chassis. Each module is specified by its serial number.

# GFT1404, 8 Channel Digital Delay Generator

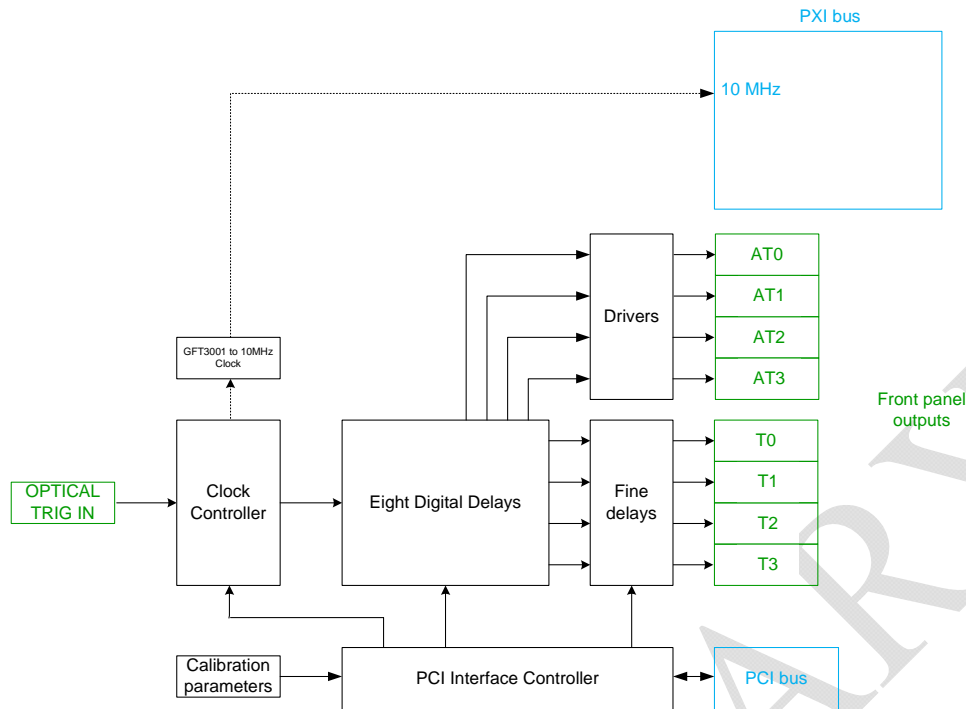

## SPECIFICATIONS

### Input trigger

Trigger	optical trigger with GFT3001 Single shot and repetitive
Sensitivity	- 28 dBm
Saturation	- 8 dBm
Wavelength	1260 to 1550 nm

### Delays T0 to T3

Channels	4 independent delay outputs
Range	0 to > 20 seconds
Resolution	1 ps
Jitter	50 ps rms + delay x 10 <sup>-7</sup> (1) (GFT3001 to any output)
Accuracy	< 250 ps + delay x 10 <sup>-7</sup> (1)

### Auxiliary Delays AT0 to AT3

Channels	4 independent delay outputs
Range	0 to > 20 seconds
Resolution	6.43 ns (One period of CLK)
Jitter	< 100 ps rms + delay x 10 <sup>-7</sup> (1) (GFT3001 to any output)
Accuracy	1 ns + delay x 10 <sup>-7</sup> (1)

### General specifications

Size	PXI, 3U, 1 slot
Power	15 W (+ 3.3 V / + 5 V / + 12 V)
Leds	Red: Fault, Green: Trigger on

### Time base

Frequency:	155.52 MHz
------------	------------

### Output T0 to T3

Amplitude	2 to 5 V
Width	200 ns to 10 μs
Load	50 Ω
Rise/Fall time	< 2 ns
Connector	SMB

### Auxiliary Output AT0 to AT3

Amplitude	5 V
Width	< 20 ns to 10 ms
Load	50 Ω
Rise/Fall time	< 5 ns
Connector	MMCX

### Software

Free Drivers for Windows XP/Vista  
NI-VISA and LabVIEW driver  
Control panel software for Windows

### Options

Optical output, frequency time base, 10 MHz PXI clock