



# GFT1218

## 8 Channel Digital Delay Generator

- Eight Independent Delay Channel
- 1 ps resolution
- 15 ps rms jitter
- 1 second delay range
- cPCI 6U, 1 slot

### Applications

- Components Test
- ATE Application
- Laser Timing application
- Precision Pulse Application
- Picosecond timing system
- Triggering

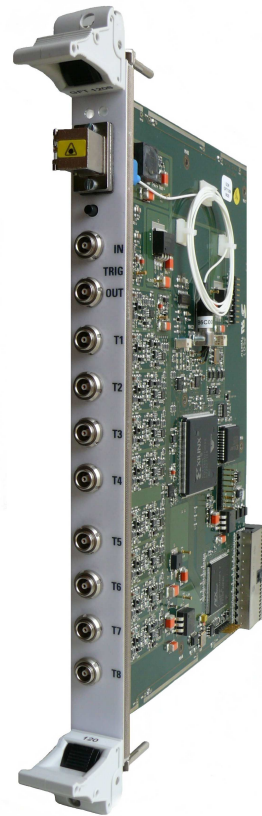

### Description

The GFT1208 module provides eight independent delay channels. The delay resolution on all channels is < 1 ps and channel to channel jitter is less than 15 ps.

LEMO outputs deliver 2.15 to 10 V level under 50  $\Omega$ . One T0 channel (zero delay) is used to reference the eight output channel in different operation modes.

One input channel is used to trigger off all output channels.

In system mode, the module could be optical triggered by GFT3001 via an optical network.

## *GFT1218, 8 Channel Digital Delay Generator*

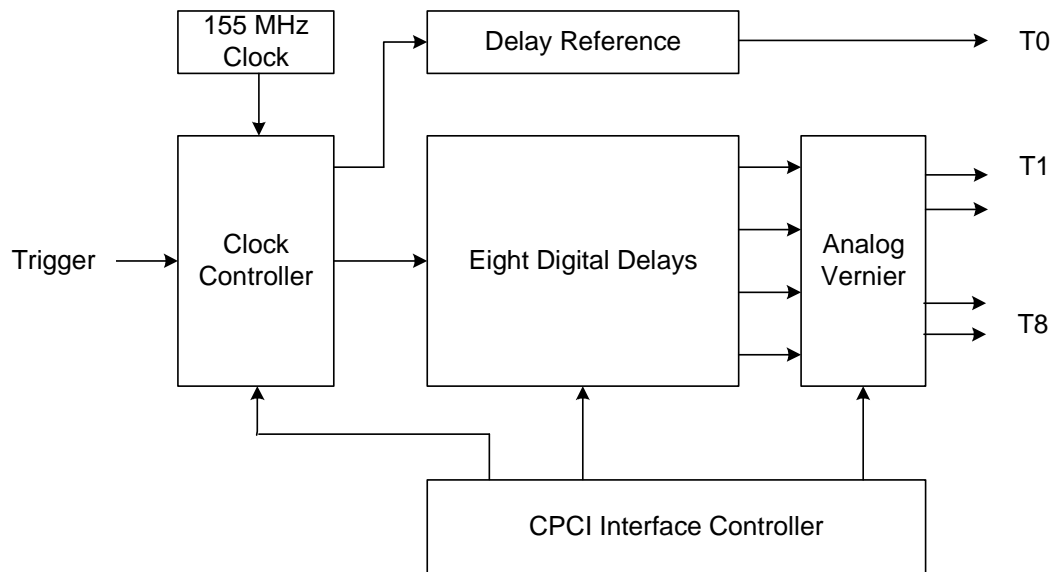

### **Specifications**

#### **Delays**

Channels	One fixed position marker (T0) and 8 independent delay
Range	0 to 10 s
Resolution	1 ps
RMS jitter (T0 to any output)	15 ps rms
RMS jitter (External Trigger to any output)	50 ps+ $10^{-7}$ x delay
Trigger Delay	< 100 ns (insertion delay)
Accuracy	< 250 ps + delay x $10^{-7}$
Timebase	10 MHz internal clock
Repetition Rate	< 50 kHz
External Trigger	Level 1V, slope positive, impedance 50 $\Omega$
Internal Trigger	0.05 Hz to 50 kHz, resolution : 1 Hz

#### **Output**

Amplitude	2.5 to 10 V, resolution : 1 mV
Width	200 ns to 1 $\mu$ s
Load	50 $\Omega$
Rise time, fall time	< 2 ns, < 5 ns
Connector	LEMO

#### **General**

Size	CPCI, 1 slot
------	--------------

#### **Free Drivers for 2000/XP**

#### **Options**

Option 1	Optical triggered
----------	-------------------